



Advanced Matrix Technology, Inc.

AMT ACCEL-635 AMT ACCEL-535

User's Guide

Unpacking

Set Up

Loading Paper

Control Panel

Cleaning & Maintenance

Solving Problems

Bottom-Feed Tractors

Bar Codes

Interfaces

Code Sets

Specifications

Document No. 367001 • Revision A

ADVANCED MATRIX TECHNOLOGY, INC.
747 Calle Plano
Camarillo, CA 93012-8598

TEL: (805) 388-5799 FAX: (805) 484-5282

Printing a Self Test

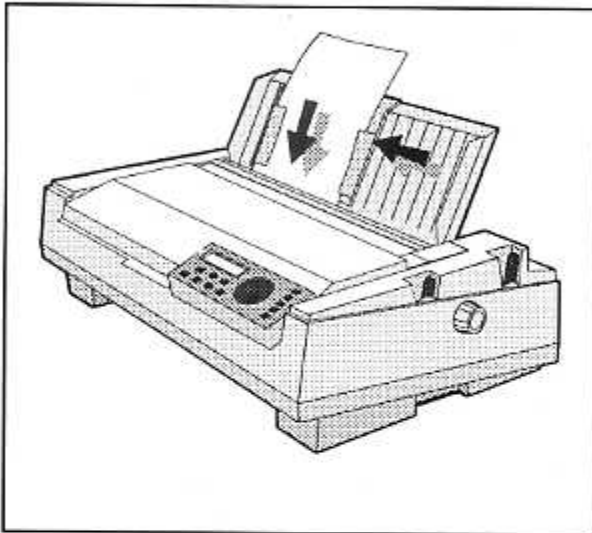

Figure 2-19. Loading a Cut Sheet

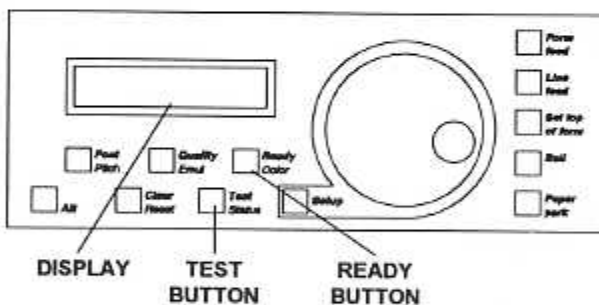

Figure 2-20. Printing a Self Test

Self test lets you verify normal printing operation and inspect print quality. You should print a self test after installing the printer, after preventive maintenance, after extended periods of inactivity, and during troubleshooting when applicable.

To print a self test, perform this procedure:

1. With the paper support raised, set a sheet of paper between the paper edge guides, as shown in figure 2-19. Make sure that the left paper edge guide is aligned with the red "0" mark (| 0) on the ruler and that the right paper edge guide is against the right side of the paper.
2. To print an 8-inch-wide self test, press the Test button, as shown in figure 2-20. To print a 13.6-inch-wide self test, press the Test button twice in succession. The paper will feed into the printer, the TEST message will display on the control panel, and the self test will begin printing.
✎ Only on 535, 535d, 535si and 535dsi models: While printing, move the forms thickness indicator as needed to optimize the print quality.
3. To stop the self test, press the Ready button. The printer will stop printing after completing the current line and the PAUSE message will appear.
4. Inspect the printout. Make sure that the characters are dark and crisp. If the quality is unacceptable, install a new ribbon cartridge and try again.

Section

3

Loading Paper

This section describes how to load various kinds of media into the printer, including single sheets, pin-feed paper, multipart forms, labels, and transparencies. If your printer has bottom-feed forms tractors (that is, it is a 635d, 535d or 535dsi), please refer to the appendix *Bottom Feed Tractors* for information on loading paper from the bottom of the printer.

Choosing Paper

The printer can accommodate many different sizes and types of paper:

- ✓ Single sheets must be from 4 to 17 inches wide, at least 3 inches long, and can be up to 0.015 inch thick.
- ✓ Pin-feed paper must be from 3 to 16.5 inches wide including the perforated edge strips, and can be up to 0.015 inch thick.
- ✓ Multipart forms can have up to seven parts with carbons, and can be up to 0.024 inch thick. Or, if your printer has a super-impact print-head (that is, it is a 535si or 535dsi), multipart forms can have up to twelve parts with carbons, and can be up to 0.040 inch thick.
- ✓ Labels and transparencies must also conform to the preceding dimensions. Transparencies require an ink-absorbent coating and paper backing sheets. You can purchase dot-matrix transparency material at most computer and printer supply outlets.

Paper Paths

The printer has three separate paper paths that you can use to load various types of paper.

- ✓ *Top path.* You use this path to feed single sheets and forms. You can load sheets manually or with an automatic sheetfeeder option.

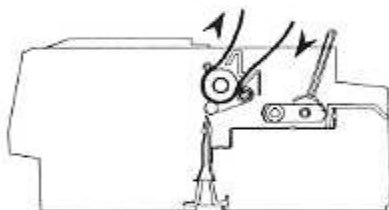

- ✓ *Rear path.* You use this path to feed pin-feed media from the rear of the printer.

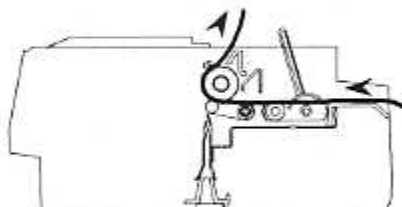

- ✓ *Bottom path.* If your printer has bottom-feed forms tractors (that is, it is a 635d, 535d or 535dsi), you use this path to feed pin-feed media from the bottom of the printer. This bottom path is ideal for thick multipart forms that do not bend easily. The bottom path supports paper movement in both directions.

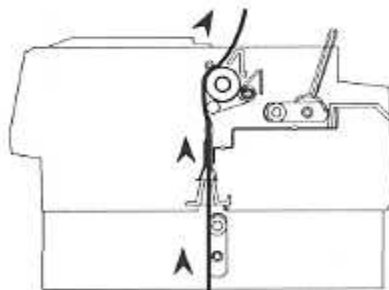

▮ **Note:** If your printer does not have bottom-feed forms tractors, you can purchase a top-pull tractor option that allows you to load pin-feed forms from the bottom of the printer. This option only supports forward paper movement.

Selecting a Paper Path

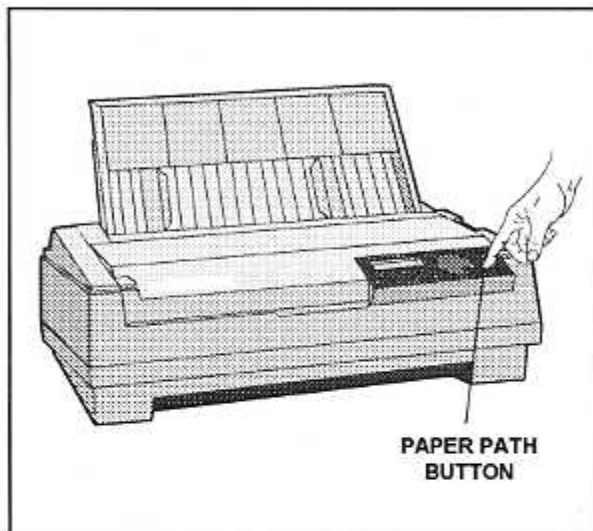

Figure 3-1. Selecting a Paper Path on 635 and 635d Models

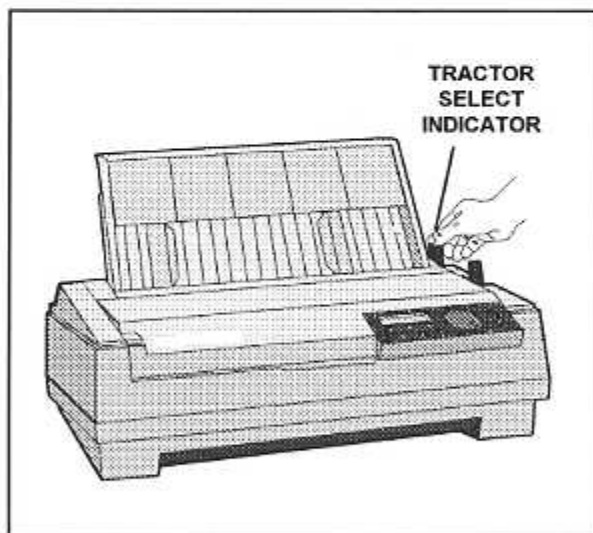

Figure 3-2. Selecting a Paper Path on 535, 535d, 535si and 535dsi Models

The tractor select indicator indicates which paper path is selected:

- ☐ *Rear position:* In the rear position, the top or bottom paper path is selected.
- ☐ *Front position:* In the front position, the rear paper path is selected.

To select a paper path, perform one of the following actions, depending on the model:

- ✓ **On 635 and 635d models:** Press the Paper path button on the control panel (see figure 3-1) as necessary to cycle through the paper path selections. The paper path that appears on the control panel display indicates the active path:

PATH:	TOP
-------	-----

PATH:	REAR
-------	------

PATH:	BOTTOM
-------	--------

After you select a paper path, the tractor select indicator will move to the correct position automatically.

- ✓ **On 535, 535d, 535si and 535dsi models:** Manually move the tractor select indicator to the desired position (see figure 3-2).

☞ **Note:** To select the bottom paper path, you also have to change the PATH parameter on the printer's Setup menu. Refer to the *Bottom-Feed Tractors* appendix for more information.

Loading Single Sheets

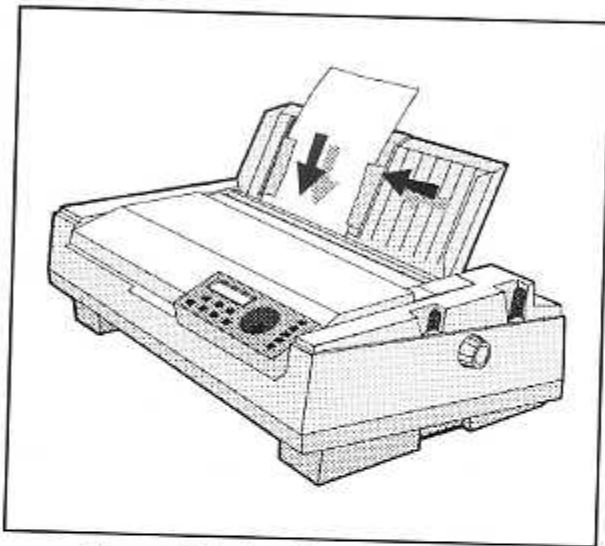



Figure 3-3. Loading a Single Sheet

You load single sheets from the top of the printer. After loading a sheet, the printer automatically positions the sheet to the first printable line. After printing, the printer ejects the sheet. If the printer has more information to print, the LOAD PAPER message appears on the control panel display to notify you.

To load a single sheet, use this procedure:

1. Select the top paper path ().
2. Raise the paper support and slide the left paper edge guide so that it aligns with the red "0" mark () on the paper scale.
3. Set a single sheet into the left paper edge guide and slide the right paper edge guide up against the right edge of the paper, as shown in figure 3-3.
4. Press the Form feed button. The sheet will advance into the printer. If printing does not begin within about 30 seconds, the printer advances the page one inch and captures the page under the bail. When printing does begin, the printer reverse feeds the page to the first printable line. As printing continues, the printer automatically recaptures the page under the bail.

Loading Single Sheets—continued

☞ **Note:** To load sheets wider than 16 inches, don't use the paper edge guides. Just set a sheet into the paper entry slot behind the platen and let it rest against the paper support. If necessary, you can remove the edge guides.

⚠ **Caution:** When loading a cut sheet, do not turn off or reset the printer until the sheet is captured under the bail. If you do, a paper jam may result during the next form feed.

You can load single sheets with pin-feed paper already loaded, provided that the pin-feed paper is in the *parked* position. You'll learn more about *paper park* later in this section. With a sheetfeeder option, you can load single sheets continually without operator intervention. For information on installing and operating a sheetfeeder option, refer to the *User's Guide* that came with the option.

Positioning a Single Sheet

If necessary, you can reposition a single sheet after loading it. To do so, press the Ready button to disable printing. Then, turn the Select-dial either *clockwise* to advance the sheet or *counterclockwise* to reverse feed the sheet. Then, press the Ready button again to enable printing.

Ejecting a Single Sheet

The printer ejects a single sheet under any of the following conditions:

- ✓ When instructed by your software application.
- ✓ When printing reaches the last print line on the page.
- ✓ When printing reaches the number of lines you or your software application specified for a page.
- ✓ When automatic form feeding is on and printing reaches a half-inch from the bottom of the page.
- ✓ When you press the Form feed button on the control panel.

Loading Pin-Feed Paper

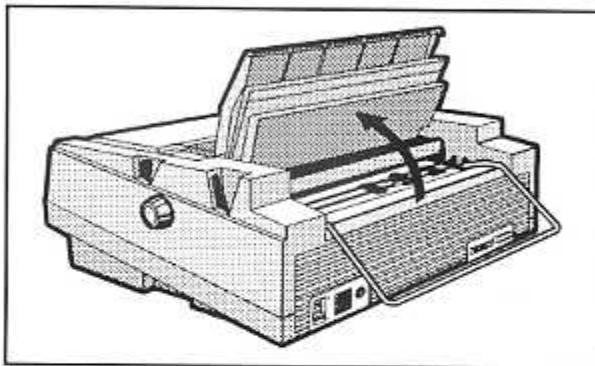

Figure 3-4. Raising the Tractor Cover

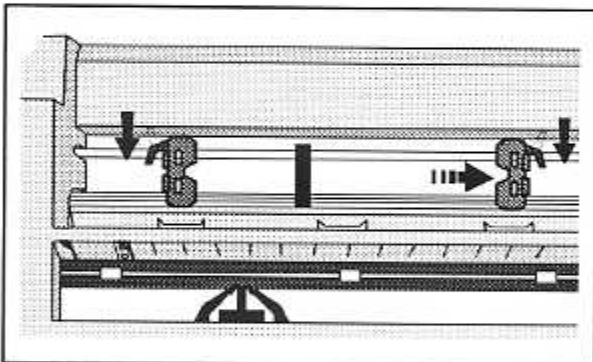

Figure 3-5. Unlocking the Tractors

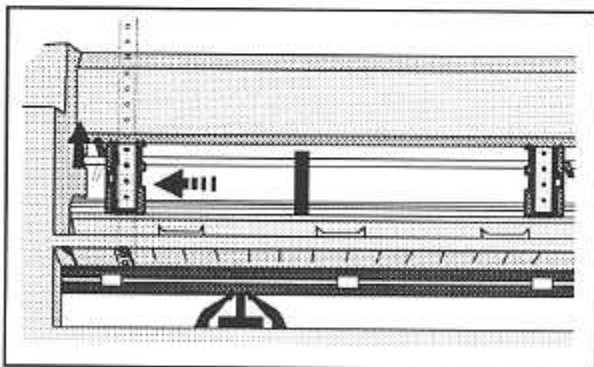

Figure 3-6. Aligning the Left Tractor

The printer contains two built-in, low-profile tractors that are easy to load. Normally, you load pin-feed paper from the back of the printer. After loading paper, the printer automatically advances the paper to the first printable line. When printing is completed on the first page, the printer advances the paper to the next sheet, again to the first printable line. This cycle continues for as long as the paper supply lasts.

If your printer has bottom-feed forms tractors (that is, it is a 635d, 535d or 535dsi), please refer to the *Bottom-Feed Tractors* appendix in this guide for information on loading paper from the bottom.

To load pin-feed paper in the printer, use the following procedure:

1. Select the rear paper path (ⓑ).
2. Raise the paper support and lift up the cover that extends over the forms tractors, as shown in figure 3-4.
3. Unlock both tractors by moving the locking levers, as shown in figure 3-5.
4. Slide the left tractor as needed so that the pin belt aligns with the circles on the paper scale. Then, lock the left tractor into place, as shown in figure 3-6.
5. Open both tractor doors.

Loading Pin-Feed Paper—continued

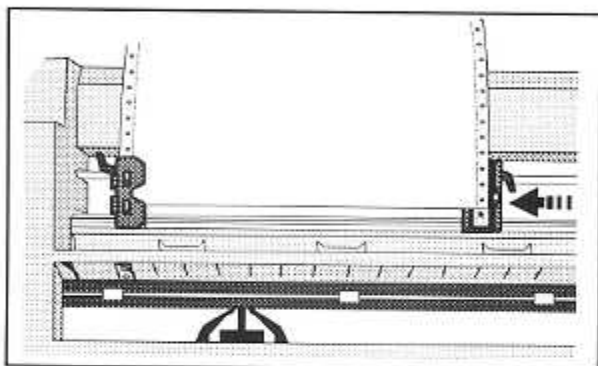

Figure 3-7. Loading Paper Into the Tractors

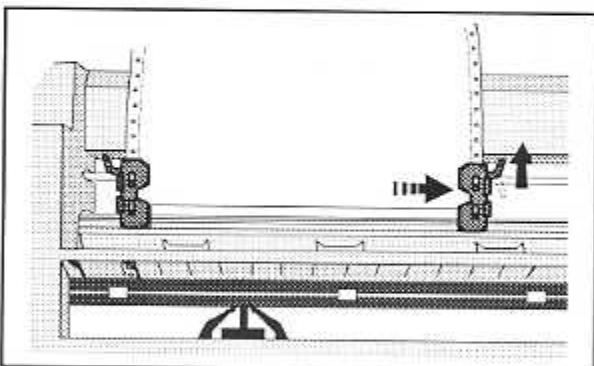

Figure 3-8. Making Sure the Paper is Taut

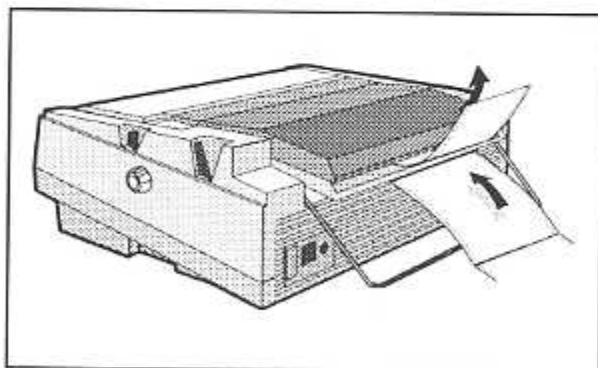

Figure 3-9. Checking the Exit Path

6. Mount the paper onto the first three pins of both tractors, as shown in figure 3-7, and close the tractor doors. You'll need to slide the right tractor left or right as needed until its pin belt aligns with the paper holes.
 7. Slide the right tractor as needed to make the paper just slightly taut between the tractors, as shown in figure 3-8. Then, lock the right tractor into place.
 8. Lower the tractor cover, paper support and printer window.
 9. Press the Form feed button on the control panel. The printer advances the paper to the first printable line. After printing begins, make sure the paper exits the printer from under the printer window, as shown in figure 3-9.
- ☛ **Only on 535, 535d, 535si and 535dsi models:** While printing, move the forms thickness indicator as needed to optimize the print quality.
 - ☛ **Caution:** When loading pin-feed paper, do not turn off or reset the printer until the first page is captured under the bail. If you do, a paper jam may result during the next form feed.

Positioning Pin-Feed Paper

Although it is usually unnecessary, you can move pin-feed paper forward or backward after loading it. To move pin-feed paper, press the Ready button to disable printing and then turn the Select-dial. Turning the dial *clockwise* advances the paper; turning the dial *counterclockwise* reverse feeds the paper. After positioning the paper, press the Ready button again to re-enable printing.

Advancing Pin-Feed Paper

The printer advances pin-feed paper to the next sheet under any of the following conditions:

- ✓ When instructed by your software application.
- ✓ When printing reaches the number of lines you or your software application specified.
- ✓ When automatic form feeding is on and printing reaches a half inch from the bottom of the page.
- ✓ When you press the Form feed button on the control panel.

Using the Demand Document Mode

Demand document mode automatically presents forms for tear off

A special feature of the printer is the demand document mode. Demand document lets you remove a sheet of pin-feed paper without wasting the next sheet. This is especially useful when printing serialized checks or forms where you must account for each page.

To use the demand document mode, you must first remove the sound window to expose the serrated tear bar on the platen window. To remove the sound window, gently lift up the tabs at the left and right edges of the top cover.

Using the Demand Document Mode—continued

With demand document mode on, pressing the Ready button on the control panel disables printing, displays the DEMND message (instead of the PAUSE message), and advances the bottom of the last printed page to the tear bar. You can then tear off and remove the page.

The printer automatically senses whether or not you tear off the page. Pressing the Ready button again causes one of the following actions:

- ✓ If you *removed* the last printed page, the paper reverse feeds to the next top-of-form, the READY message reappears, and printing continues.
- ✓ If you *did not remove* the last printed page, the paper reverse feeds to its original position, the READY message reappears, and printing continues at the point where it left off.

Normally, the demand document mode is off. To turn on the demand document mode, use the following procedure:

OPERATIONS

With the printer paused or idle, press the Setup button on the control panel to access the Setup menu.

24) DEMAND: Off

Turn the Select-dial until the DEMAND parameter appears on the display.

24) DEMAND: On

While holding down the Alt button, turn the Select-dial until *On* appears. Then, release the Alt button.

COURIER LQ READY

Press the Setup button again to return to the status message display.

Using the Demand Document Mode—continued

Instead of selecting *On* at the DEMAND parameter, you can select *Beep*, *Tear* or *Auto*. These options also select the demand document mode, but with special options:

- ✓ *Beep* causes the printer to begin *beeping* 15 seconds after you press the Ready button to pause printing. This *beeping* serves as a reminder to press the Ready button again to re-enable printing.
- ✓ *Tear* causes the printer to reverse feed the paper to the next top-of-form when you re-enable printing, whether or not you actually tear off the last printed sheet. This option is useful when printing thick multipart forms that jam when the leading edge of the form is reverse fed below the printhead.
- ✓ *Auto* causes the printer to advance the bottom of the last printed page to the tear bar whenever the printer is idle—you don't have to press the Ready button. As soon as the printer receives subsequent data to print, the paper reverse feeds as usual.

If you want to stop printing mid-form without advancing the perforation to the tear bar, press the Ready button twice in succession. This disables printing and displays the PAUSE message. Pressing the Ready button again re-enables printing and displays the READY message. These are the normal ready/pause conditions of the printer. You'll learn more about them in the *Control Panel* section of this guide.

Using Paper Park

With the paper park feature, reversing pin-feed paper out of the printer is quick and easy. Reloading paper is even easier. With pin-feed paper parked, you can load a cut sheet.

To park pin-feed paper, use the following procedure:

1. Tear off the last printed sheet at the perforation.
2. Press the Paper park button on the control panel. The printer reverse feeds the paper until the leading edge of the first sheet is halfway through the tractors.

✎ **Only on 535, 535d, 535si and 535dsi models:** After the paper parks, the message CHECK TRACTR LVR appears on the control panel display to remind you to set the tractor select indicator *if you are going to load a single sheet into the printer*. Setting this indicator to the rear position disengages the built-in forms tractors and enables single-sheet mode. If you forget to set this indicator, a paper jam can result since both the single sheet and the pin-feed paper will feed into the printer at the same time. If you are *not* going to load a single sheet, just ignore the message. Pressing the Ready button or setting the tractor select indicator clears the message.

To reload the pin-feed paper, press the Form feed button on the control panel. The printer advances the paper to the first printable line.

To load a single sheet, select the top paper path (5). Then, load the sheet in the usual way (refer to *Loading Single Sheets* in this section).

Unloading Pin-Feed Paper

To unload pin-feed paper, tear off all printed pages that have exited the printer and press the Paper park button on the control panel. Then, turn the Select-dial *counterclockwise* until the pin-feed paper is clear of the tractors.

Loading Multipart Forms

AMT ACCEL-635, -635d, -535 and -535d models can handle individually-cut or pin-feed forms containing up to seven parts and carbons. AMT ACCEL-535si and -535dsi models can handle forms containing up to twelve parts and carbons. The procedures for loading multipart forms are the same as those for loading single sheets and pin-feed paper, except for the following precautions:

- ✓ Forms are thicker than normal paper. The 635 and 635d models can automatically detect and compensate for thicker forms. On 535, 535d, 535si and 535dsi models, however, you must manually adjust the forms thickness indicator. Always start with the indicator all the way towards the front of the printer, then slowly push it back until print density is optimized.
- ✓ If your printer has bottom-feed tractors or you have a top-mounted pull tractor option, load forms from the bottom of the printer, especially forms that do not bend easily or tear apart when you bend them. When forms enter the printer from the bottom, they feed straight through the printer without having to bend around the platen.

Loading Labels

Your printer can handle individual labels or those with a pin-feed backing sheet. The procedures for loading labels are the same as those for loading single sheets or pin-feed paper, except for the following precautions:

- ✓ Labels are thicker than normal paper. The 635 and 635d models can automatically detect and compensate for thicker labels. On 535, 535d, 535si and 535dsi models, however, you must manually adjust the forms thickness indicator. Always start with the indicator all the way towards the front of the printer, then slowly push it back until print density is optimized.
- ✓ When feeding labels, do not use reverse feed, paper park, or the demand document mode. When labels reverse feed, they can peel off the backing and jam in the printer. To avoid reverse feeding when you are ready to remove labels from the printer, tear them off at a

Loading Labels—continued

perforation that has not yet entered the printer. Then, press the Form feed button to eject any labels remaining in the printer.

- ✓ If your printer has bottom-feed tractors or you have a top-mounted pull tractor option, load labels from the bottom of the printer, especially labels that easily peel off the backing. When labels enter the printer from the bottom, they feed straight through the printer without having to bend around the platen.

Loading Transparencies

Your printer can handle individually-cut or pin-feed transparencies made for dot-matrix printers. Dot-matrix transparencies contain an ink-absorbent coating to reduce smearing and a paper backing so printer sensors can detect when a transparency is loaded. The procedures for loading transparencies are the same as those for loading single sheets or pin-feed paper, except for the following precautions:

- ✓ Transparencies are thicker than normal paper. The 635 and 635d models can automatically detect and compensate for thicker transparencies. On 535, 535d, 535si and 535dsi models, however, you must manually adjust the forms thickness indicator. Always start with the indicator all the way towards the front of the printer, then slowly push it back until print density is optimized.
- ✓ For best results when printing on transparencies, use a fairly new ribbon. A ribbon that is more than half way through its useful life may not transfer enough ink onto the transparency for acceptable projection.

Aligning Preprinted Forms

When you print on preprinted forms, paper alignment is critical. To align a preprinted form in the printer, use the following procedure:

1. With the printer idle, press the Setup button on the control panel to access the Setup menu. Turn the Select-dial until the POPUP parameter appears. Hold down the Alt button and turn the Select-dial until *On* appears; then release the Alt button. Press the Setup button again.
2. Load the preprinted form into the printer.
3. Press the Ready button to disable printing and then turn the Select-dial as needed to align the first print line on the form with the top edge of the ribbon shield. Then, press the Ready button again.
4. Press the Setup button to access the Setup menu. Turn the Select-dial until the LFT MAR parameter appears on the display.
5. While holding down the Alt button, turn the Select-dial as needed to position the printhead over the first print position on the form. Then, release the Alt button.
6. Press the Setup button again.

Setting Page Length

If the printer's page length setting does not reflect the actual current page length, the following problems can occur:

- ✓ Printing may continue beyond the bottom edge of the page.
- ✓ The page may eject before printing is finished.
- ✓ Pin-feed paper may not advance to the correct top-of-form position. Typically, the amount of error increases in proportion to the number of pages you feed.

Ordinarily, software applications set page length for you. If you experience one of these problems, you may have to set the page length manually.

Setting Page Length—continued

To set the page length, use the following procedure:

1. Press the Setup button on the control panel to access the Setup menu. Then, turn the Select-dial until the LENG parameter appears on the display.
2. While holding down the Alt button, turn the Select-dial until the LENG setting equals the actual page length in 1/6-inch increments. For example, if the actual page length is 14 inches, the setting would be 84 (14" x 6). Then, release the Alt button.
3. Press the Setup button to return to the status message.

☞ **Note:** The page length setting is defined in one-sixth inch increments regardless of the current lines per inch setting.

Positioning the Sound Window

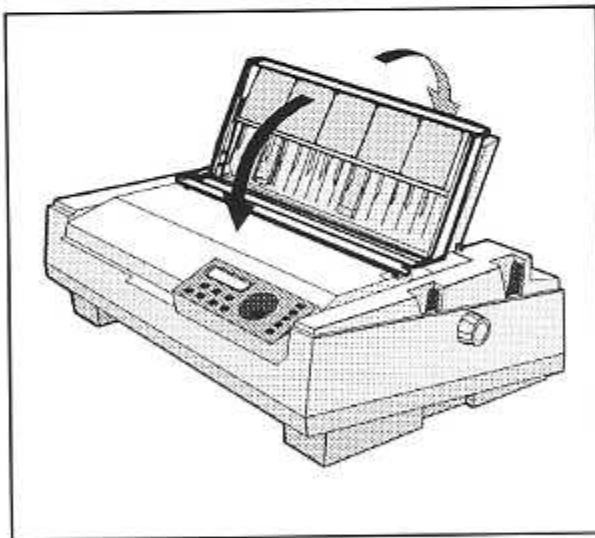

Figure 3-10. Positioning the Sound Window

When using the sound window, you should place it in one of three positions, depending on whether the paper support is up or down:

- ✓ With the paper support raised, the sound window should rest lightly against it, as shown in figure 3-10. *Do not* press the window over the sides of the paper support, since this obstructs the paper path.
- ✓ With the paper support lowered, the sound window *should be* pressed down over the sides of the paper support. This position helps reduce noise.
- ✓ At any time, you can pull the sound window forward. This allows access to the tear bar and paper entry slot.

Reviewing the Paper Handling Controls

Here's a brief review of the paper handling controls:

- ✓ *Tractor select indicator* shows which paper path is selected. When loading pin-feed paper from the rear, the indicator must be towards the *front* of the printer. When loading single sheets or pin-feed paper from the bottom, the indicator must be towards the *rear* of the printer. On 635 and 635d models, you select a paper path by pressing the Paper path button. On 535, 535d, 535si and 535dsi models, you select a paper path by manually moving the indicator.
- ✓ *Forms thickness indicator* shows the current forms thickness. On 635 and 635d models, the printer automatically detects forms thickness and adjusts this indicator accordingly. On 535, 535d, 535si and 535dsi models, you move this indicator manually to optimize print quality.
- ✓ *Form feed button* feeds a single sheet to the top-of-form, ejects a single sheet, and advances pin-feed paper to the next top-of-form. After a form feed, the line count is zero, except when a top margin is set.
- ✓ *Line feed button* advances the paper one line space. The actual distance the paper moves for one line space is set by software or from the control panel. You can hold down the Line feed button for continuous line feeding. With each line feed operation, the line count increases by one.
- ✓ *Set top of form button* sets the top-of-form at the current print line. The printer recognizes the current print line as the first line on the page (line 0) and starts counting lines from there.
- ✓ *Paper path button* (on 635 and 635d models only) lets you select a paper path. After you make your selection, the tractor select indicator will move automatically to the correct position.

Reviewing Paper Handling Controls—continued

- ✓ *Bail button* engages and disengages the bail. During paper loading, bail motion is automatic so you will rarely use this button. Pressing the button moves the bail away from the platen so you can clear a paper jam or clean the platen. Pressing the button again moves the bail back against the platen. 635 and 635d models do not have this button. To move the bail on these models, hold down the Alt button and press the Paper park button.
- ✓ *Paper park button* reverse feeds pin-feed paper until the leading edge of the first sheet is halfway through the tractors. Paper park is the easiest way to unload pin-feed paper from the printer, although it should not be performed with labels or multipart forms. To reload the paper, just press the Form feed button.
- ✓ *Select-dial* has these paper handling functions:
 - With printing paused, turning the dial *clockwise* advances the paper through the printer; turning the dial *counterclockwise* reverse feeds the paper.
 - With printing paused, holding down the Alt button and turning the Select-dial moves the printer carriage. Turning the dial *clockwise* moves the carriage right; turning the dial *counterclockwise* moves the carriage left.

Section

4

Control Panel

This section describes how to use the printer's control panel, which is shown in figures 4-1 and 4-2. The control panel consists of a sixteen-character display, twelve buttons and a Select-dial.

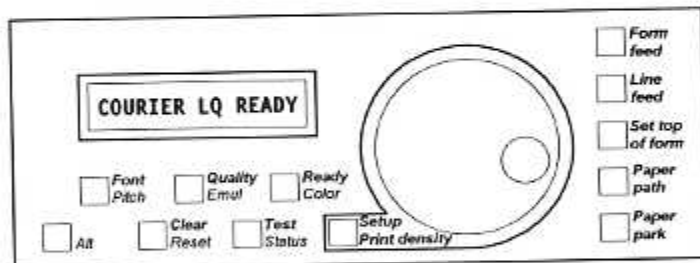

Figure 4-1. Control Panel, AMT ACCEL-635 Series

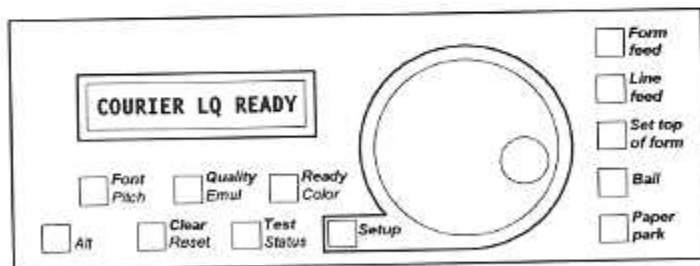

Figure 4-2. Control Panel, AMT ACCEL-535 Series

Understanding Display Messages

The control panel display can show four kinds of messages.

COURIER LQ READY *Status*

The *status* message appears when you turn on the printer and during normal printing operations. This message shows the current font and print quality, and whether the printer is ready, paused, printing a self test, or in demand document mode. Notice that the button that controls each displayed setting is located just below the displayed setting.



10 DIAB630 BLACK *Alternate Status*

The *alternate status* message appears when you press the Alt button to invoke the alternate function of a button. The alternate function is printed in blue alongside the button. The message shows the current character pitch (the number of characters per inch), printer emulation, and color. Notice that the button that controls each displayed setting is located just below the displayed setting.

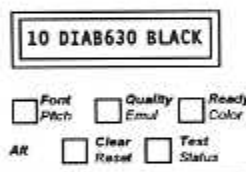

LOAD PAPER *Operator and Error*

Many *operator and error* messages appear to notify you of printer conditions, actions you must take, and errors that occur. You can find a complete list of operator and error messages in the *Solving Problems* section of this guide.

33) INTRFCE: Par *Setup Menu*

The *Setup menu* is a list of parameters for operations, print modes, page setup, tabs, communications, and special modes. The menu provides a snapshot view of current printer status. You can change settings as required, then save the settings for use at a later time. You can also specify the power-on default settings. You'll learn more about the Setup menu later in this section.

Using the Select-Dial

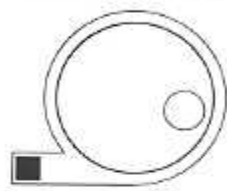

You turn the Select-dial to move the paper up and down, move the carriage back and forth, scroll through the Setup menu, and fine adjust the automatic print density control on 635 and 635d models.

Moving the Paper Up and Down

To move the paper up and down, press the Ready button to disable printing and then turn the Select-dial. To advance the paper, turn the dial *clockwise*; to reverse-feed the paper, turn the dial *counterclockwise*. After moving the paper, press the Ready button again to re-enable printing. When you move the paper with the dial, printer logic does not change the internal line count. This enables you to decide where the first print line should be and where line counting begins.

Moving the Carriage Back and Forth

To move the carriage to the right, hold down the Alt button and turn the dial *clockwise*. To move the carriage to the left, hold down the Alt button and turn the dial *counterclockwise*. You may have to move the carriage to install a ribbon cartridge or clear a paper jam. Moving the carriage does not affect the printer position. When printing begins, the carriage moves back to its original position.

Scrolling Through the Setup Menu

Whenever the Setup menu is displayed, you use the Select-dial to scroll through the menu and make selections. You'll learn how to make selections later in this section.

Fine Adjusting Print Density (635 and 635d Models Only)

To fine adjust the automatic print density control on 635 and 635d models, hold down the Print density button and turn the Select-dial. A print density adjustment scale appears on the display to show you the adjustment range. To make printing darker, turn the dial *clockwise*; to make printing lighter, turn the dial *counterclockwise*. This fine-adjustment affects both automatically-set and user-defined density settings. The printer will retain this adjustment even when turned off.

Using the Control Panel Buttons

You press the buttons to set printer parameters and perform operations. A white function label is printed next to each button to remind you of its primary function and a blue label to remind you of its alternate function. To invoke the primary function of a button, just press the button. To invoke the alternate function of a button, hold down the Alt button and press the button.

Only the Ready button operates while printing is in progress. To use any other button while printing, you must first press the Ready button and wait for printing to pause. When you change a printer setting with a control panel button, the printer *beeps* to confirm the change.

Turning Printing On and Off



Pressing the Ready button turns printing on or off, and displays either READY or PAUSE. With READY displayed, the printer is free to print any data it receives. With PAUSE displayed, printing cannot occur. If you press the Ready button while printing is in progress, printing will stop at the end of the current line. When you press the Ready button again, printing will continue where it left off.

When the demand document mode is on, pressing the Ready button turns printing off, displays DEMND on the control panel, and advances the bottom edge of the last printed page up to the serrated tear bar. You can then tear off and remove the page if you want to. Pressing the Ready button again performs one of the following actions:

- ✓ If you *removed* the last printed page or you are using the *Tear* setting, the paper reverse-feeds to the next top-of-form, the READY message reappears, and printing continues.
- ✓ If you *did not remove* the last printed page, the paper reverse-feeds to its original position, the READY message reappears, and printing continues at the point where it left off.

Also when the demand document mode is on, pressing the Ready button twice in succession disables printing and displays PAUSE on the control panel without advancing the form up to the tear bar. Pressing the Ready button again re-enables printing and the READY message reappears.

Selecting a Printer Emulation

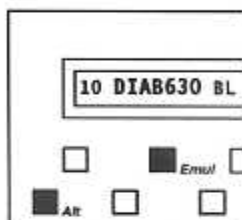

Holding down the Alt button and pressing the Emul button selects the next available printer emulation and displays the name of the printer being emulated. The emulations you can choose from consist of those in the installed Intelli-card(s). On standard printers you can select from the following emulations: AMT (AMT's native language), DIAB630 (the Diablo 630 daisywheel printer), EPSONJX (the Epson JX color dot-matrix printer), EPSONLQ (the Epson LQ-2550 color dot-matrix printer), and IBMXL24 (the IBM Proprinter XL24 color dot-matrix printer). When you select an emulation, all current printer settings remain in effect.

Note: Emulations allow your printer to operate just like printers from other manufacturers, such as Epson or IBM. By emulating other popular printers, your printer becomes compatible with a wider range of software applications.

Selecting a Text Quality

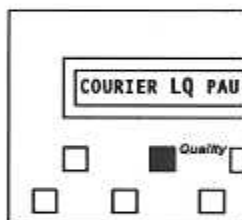

Pressing the Quality button selects the next text quality and displays one of the following: LQ for letter-quality, MQ for memo-quality, and DQ for draft-quality.

The actual print speed for each text quality depends on your printer model and current pitch setting. Print speeds are listed in the *Specifications* appendix of this guide.

Selecting a Font

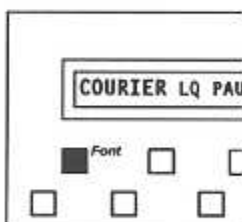

Pressing the Font button selects the next available font (type style) and displays the font name. The fonts you can choose from consist of those in the installed Intelli-card(s) and those that you download from your computer. On standard printers you can select from the following fonts: COURIER (a fixed-pitch serif font), GOTHIC (a fixed pitch sans-serif font), TREND (a proportionally-spaced serif font), and ELITE (a fixed-pitch serif font). Each font has a default pitch, which is the number of characters per inch that you normally use to print the font. When you select a font, pitch changes to the default pitch of that font.

Selecting a Pitch

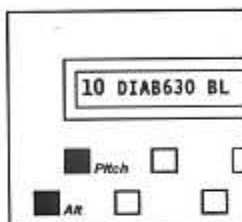

Holding down the Alt button and pressing the Pitch button selects the next available pitch (number of characters per inch) and displays the pitch setting. You can select 10, 12, 13.3, 15, 17.1 or 20 characters per inch. If the current font is a proportionally-spaced font, you can also select PS. If your software application sets the pitch to some nonstandard value, such as 5- or 8-pitch, NS (for nonstandard) appears as the current pitch. When you select a pitch, characters in the current font expand or compress to fit the new spacing.

Selecting a Color

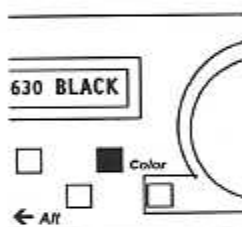

Holding down the Alt button and pressing the Color button selects the next available color and displays the name of the color. You can select BLACK, BLUE, RED, YELLOW, PURPLE, GREEN, or ORANGE. If a monochrome ribbon is installed in the printer, you can select only BLACK.

Form Feeding

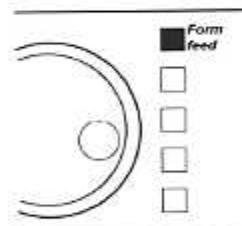

Pressing the Form feed button causes one of these actions to occur:

- ✓ If you are loading a single sheet with or without a sheetfeeder, the sheet advances to the top-of-form.
- ✓ If a single sheet is already loaded, the sheet ejects.
- ✓ If you are loading or using pin-feed paper, the paper advances to the next top-of-form.

Line Feeding



Pressing the Line feed button advances the paper one line space; holding down the Line feed button causes continuous line feeding. The actual distance that the paper advances for a line feed depends on the current lines per inch (lpi) setting. As you line feed, the printer increments the internal line count. If you use the Line feed button to move paper to the top-of-form, you must press the Set top of form button to initialize the line count to zero.

Setting the Top-of-Form

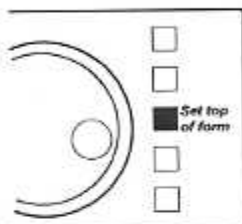

Pressing the Set top of form button sets the top-of-form at the current print line. When you set a top-of-form, the printer recognizes the current print line as the first line on the page (line 0) and starts counting lines from that point.

Selecting a Paper Path (635 and 635d Models Only)

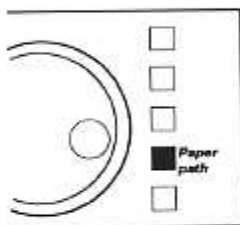

Pressing the Paper path button lets you select the top, rear or bottom paper path for subsequent paper feeding. When you first press the Paper path button, the current paper path appears on the control panel display. Pressing the Paper path button again cycles through the paper paths. After you make your selection, the tractor select indicator moves to appropriate position automatically.

☞ **Note:** On 535, 535d, 535si and 535dsi models, there is no Paper path button. To select a paper path, you must manually move the tractor select indicator and set the PATH parameter on the Setup menu.

Moving the Bail (535, 535d, 535si and 535dsi Models Only)



Pressing the Bail button moves the bail back and forth. During normal printing operations, it is *not* necessary to use the Bail button since the bail moves automatically.

☞ **Note:** On 635 and 635d models, you can move the bail by holding down the Alt button and pressing the Paper park button.

Parking the Paper

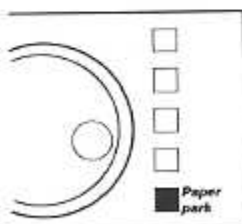

Pressing the Paper park button with pin-feed paper loaded in the printer causes the paper to reverse-feed until the top edge of the first sheet is halfway through the tractors. Before pressing the Paper park button, however, tear off the last printed sheet that has fed beyond the tear bar. With paper park, removing pin-feed paper from the printer is quick and easy. To reload paper, just press Form feed.

Clearing the Buffer

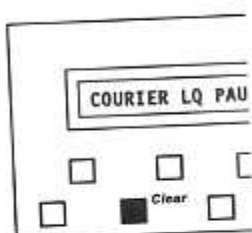

Pressing the Clear button erases any data in the printer input buffer. Since the printer receives incoming data faster than it can be printed, the printer temporarily stores data in a buffer in memory. If you turn printing off or an error occurs, you can erase all of the data in the buffer waiting to be printed. Clearing the buffer does not reset any printing parameters; all of the current settings remain in effect.

Resetting the Printer

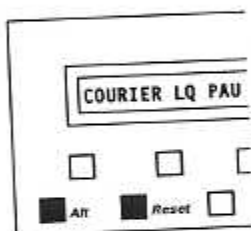

Holding down the Alt button and pressing the Reset button resets printer logic, clears the input buffer, and initializes all printing parameters to the defaults. Using the Reset button is like turning the printer off and then back on, except that downloaded fonts remain in effect.

Printing a Self Test

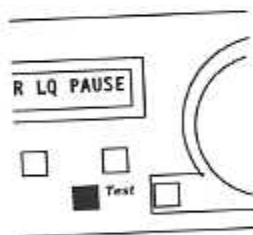

Pressing the Test button prints an 8-inch wide test pattern of some of the characters in the current font (ASCII codes 33 to 126), using the current print modes. Pressing the Test button twice in succession prints a 13.6-inch wide test pattern (or 16-inch wide test pattern, if the maximum print width is set to 16 inches). To terminate the test, press the Ready button.

```
!"#$%&'()*+,-./0123456789:;<=>?@ABCDEFGHIJKLMNPOQRSTUVWXYZ[\]^_`abcdefghijklmnopqrstuvwxyz{|}~!"#$%&'()*+,-./0123456789:;<=>?@ABCDEFGHIJKLMNPOQRSTUVWXYZ[\]^_`abcdefghijklmnopqrstuvwxyz{|}~!"#$%&'()*+,-./0123456789:;<=>?@ABCDEFGHIJKLMNPOQRSTUVWXYZ[\]^_`abcdefghijklmnopqrstuvwxyz{|}~!"#$%&'()*+,-./0123456789:;<=>?@ABCDEFGHIJKLMNPOQRSTUVWXYZ[\]^_`abcdefghijklmnopqrstuvwxyz{|}~!"#$%&'()*+,-./0123456789:;<=>?@ABCDEFGHIJKLMNPOQRSTUVWXYZ[\]^_`abcdefghijklmnopqrstuvwxyz{|}~"
```

Printing a self test is a convenient way to check that your printer is operating normally and that print quality is acceptable. Also, you can view many of the available characters in the current font.

Setting Optimal Print Density (635 and 635d Models Only)

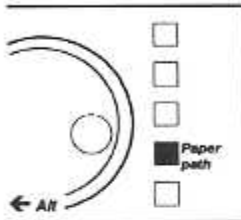

Each time you load a new form in the printer, the printhead automatically moves a fixed distance away from the form. This fixed distance provides optimal print density on most forms. If you accidentally bump the printhead or forms thickness indicator, you can have the printer reset the printhead for optimal print density by holding down the Alt button and pressing the Paper path button.

Note: If automatic forms thickness detection is disabled, holding down the Alt button and pressing the Paper path button causes the printer to reset the printhead to a user-defined position. Refer to *Set Print Density* later in this section for more information.

Fine Adjusting the Print Density (635 and 635d Models Only)

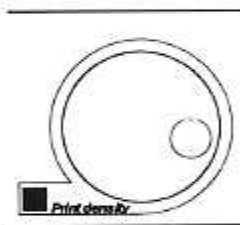

Each time you load a new form in the printer, the printhead automatically moves a fixed distance away from the form. This fixed distance is factory-set to provide optimal print density on most forms. You can fine adjust this distance if you prefer a slightly lighter or darker print. To do so:

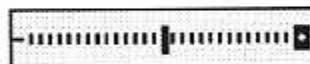

Hold down the Print density button until the print density adjustment scale appears.

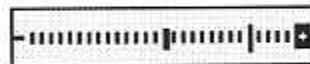

For darker print, turn the Select-dial *clockwise*. The offset indicator will move to the right.



For lighter print, turn the Select-dial *counterclockwise*. The offset indicator will move to the left.

The printer retains this adjustment even when turned off.

Note: If you try to access the adjustment scale with automatic forms thickness detection disabled, the message AUTO DENSITY OFF appears instead. Refer to *Set Print Density* later in this section for information.

Note: 535, 535d, 535si and 535dsi models do not have a Print density button. To adjust the print density, you must manually move the forms thickness indicator to optimize print density.

Printing a Printer Status Report

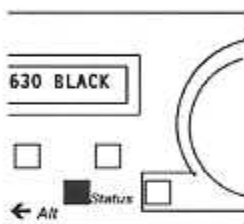

Holding down the Alt button and pressing the Status button prints a *Printer Status Report*. The report consists of a list of the available printer emulations and fonts, a printout of the Setup menu, and a printout of all characters in the current font. The Setup menu is a snap-shot view of the current printer settings. To terminate the printing of the report, just press the Ready button. Printing will stop at the end of the current line.

A sample *Printer Status Report* is shown on the next page. The settings in this example are the factory-set defaults for the AMT ACCEL-635. The factory-set defaults for other models vary slightly. Since the Setup menu is updated from time to time, your report may include additional parameters and be numbered differently. Each parameter and setting is described later in this section.

Displaying the Setup Menu

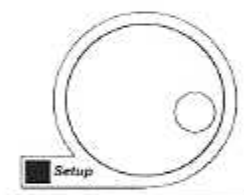

Pressing the Setup button displays the Setup menu. From the Setup menu, you can view and change most printer settings. If you display but do not use the Setup menu for more than three minutes, the status message will reappear automatically. Pressing any control panel button, except the Alt button, also redisplay the status message. Next, you'll learn more about the Setup menu.

Using the Setup Menu

The Setup menu is a selection list of printer parameters organized into the following categories:

- ✓ Operations
- ✓ Print Modes
- ✓ Page Settings
- ✓ Tabs
- ✓ Communications Settings
- ✓ Special Modes

When the Setup menu appears, the control panel display acts like a one-line window over the menu. Each line contains a different parameter. Turning the Select-dial scrolls the menu up or down below the window. Each parameter is numbered so you can always tell where you are in the menu.

Next to each parameter is the current setting for that parameter. Holding down the Alt button and turning the Select-dial cycles through the possible settings. The setting that is displayed when you release the Alt button becomes the current setting. When you change a setting, the printer *beeps* to confirm the change.

To leave the Setup menu and redisplay the status message, press the Setup button again. If you display the Setup menu but do not use it for more than three minutes, the status message reappears automatically.

You can change the current settings as required, then save them for use at a later time. You can also specify the power-on defaults for the printer to use. You can print the Setup menu using the Status button.

PARAMETER	DEFAULT SETTING	OTHER SETTINGS
OPERATIONS		
1) RSTOR:	None	Fctry Usr 1 Usr 2 Usr 3 Usr 4 Usr 5
2) SAVE:	None	Usr 1 Usr 2 Usr 3 Usr 4 Usr 5
3) DFALT:	Fctry	Usr 1 Usr 2 Usr 3 Usr 4 Usr 5
4) TEST:	None	Memory Ribbon Serial Sensor
PRINT MODES		
5) EMUL:	AMT	Diab630 EpsonJX EpsonLQ IBMXL24
6) QUAL:	Letter	Memo Draft
7) FONT:	Courier	Gothic Trend Elite
8) PITCH:	10	12 13.3 15 17.1 20 PS Other
9) CELL:	10	12 13.3 15 17.1 20 PS Other
10) LPI:	6	3 4 8 12 Other
11) COLOR:	Black	Blue Red Yellow Purpl Green Ornge
12) ITALICS:	Off	10° 20° 30°
13) HIGH:	Off	On
14) WIDE:	Off	On
15) SCRIPT:	Off	Supr Sub
16) UNDLIN:	Off	On
17) BLD/SHA:	Off	Bld Sha
18) CTR/JST:	Off	Ctr Jst
19) LANG:	USA	French German UK Danish Swedsh Italn Spnsh1 Jpnese Norwgn Danish2 Spnsh2 Portugs Uni
20) DIRCTN:	Bi-d	0 to 30
21) DENSITY:	Auto	
PAGE SETUP		
22) LENG:	66/6"	0/6" to 182/6"
23) WIDTH:	13.6	8 16
24) DEMAND:	Off	On Beep Tear Auto
25) PATH:	Top	Rear Bottom
26) BIN:	None	Front Back Envel Bottom TopTrac
27) TOP MAR:	000	0 to 181
28) BOT MAR:	066	1 to 182
29) LFT MAR:	000	0 to 319
30) RGT MAR:	136	1 to 320

Figure 4-4. Setup Menu

PARAMETER	DEFAULT SETTING	OTHER SETTINGS
TABS		
31) HOR:	SET 000	0 to 159
32) HOR OP:	None	Clr Set8
33) VER:	000	0 to 182
34) VER OP:	None	Clr
COMMUNICATIONS		
35) INTRFCE:	Auto	Par Ser
36) BAUD:	9600	150 300 600 1200 2400 4800 19200 38400
37) PARITY:	None	Odd Even
38) DAT BITS:	8	7 8M
39) STOP BITS:	1	2
40) HNDSHK:	D/X	DTR XOM ETX D/E None
41) DTR:	Pos	Neg
42) STROBE:	Neg	Pos
43) BUSY:	On	Off
44) ACK:	On	Off
SPECIAL MODES		
45) HEX MOD:	Off	On
46) BUFFER:	60K	12K 24K 36K 48K (Higher on 635 & 635d models)
47) AUTO CR:	Off	On
48) AUTO LF:	Off	On
49) AUTO FF:	Off	On
50) SETS:	IBM1	IBM2 Ital None
51) PGE END:	Off	On R11
52) SLASH-0:	Off	On
53) AUTOBAIL:	Off	On
54) PPR JAM:	On	Off
55) POPUP:	Off	On
56) BLK BAND:	Off	On

Figure 4-4. Setup Menu—continued

☞ **Note:** Learning Setup menu functions is *not* necessary. These functions are provided for users who want to explore the advanced capabilities of the printer. During normal printing, application programs control most Setup menu functions automatically.

Before describing the parameters on the Setup menu, let's review how to display, scroll through, and change settings on the Setup menu:

- | | |
|-------------------------|---|
| OPERATIONS | With the status message displayed, press the Setup button; the Setup menu appears. |
| 6) QUAL: Letter | Turn the Select-dial until the parameter you want to change appears. |
| 6) QUAL: Draft | While holding down the Alt button, turn the Select-dial to view the possible settings for the parameter. When the setting you want to select appears, release the Alt button. The printer <i>beeps</i> to confirm the setting change. |
| COURIER DQ READY | Turn the Select-dial to display another parameter or press the Setup button to redisplay the status message. |

Now that you know how to use the Setup menu, it is time to learn what each parameter does and the possible settings you can select. Parameters are described in the order they appear in the Setup menu.

Selecting Operations

The first section on the Setup menu is operations. Selecting an operation performs a specific action.

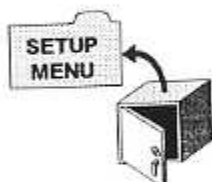

1) RSTOR: None Restore Printer Settings

RSTOR lets you restore printer settings to the factory settings or to settings you saved previously with a SAVE operation. When you use RSTOR, the printer clears the data input buffer.

You can select *None* to cancel the operation; *Fctry* to restore the factory settings; or *Usr 1* through *Usr 5* to restore the settings saved under one of these names.

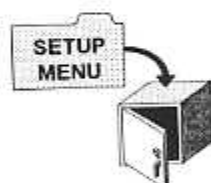

2) SAVE: None Save Printer Settings

SAVE lets you save the current printer settings in non-volatile memory for use at a later time. Non-volatile memory retains information even when the printer is turned off.

To save the current printer settings, hold down the Alt button and turn the Select-dial to select one of the five user names. As soon as you release the Alt button, the printer saves the current printer settings and assigns the user name that you select. You can use RSTOR to restore the settings you save; you can use DFALT to make your saved settings the power-on default settings.

You can select *None* to cancel the operation; or *Usr 1* through *Usr 5* to save the current settings under one of these names.

3) DFALT: Fctry *Select Power-On Default Settings*

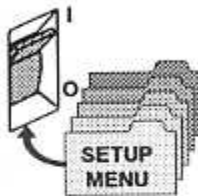

DFALT lets you select the printer settings to use as the power-on default settings. You can select the factory settings or the settings you saved previously with a SAVE operation. The printer keeps your DFALT selection in non-volatile memory so it is retained when the printer is off.

You can select *Fctry* to use the factory settings as the power-on defaults; or *Usr 1* through *Usr 5* to use the settings saved under one of these names.

4) TEST: None *Run Printer Tests*



TEST lets you run a variety of printer tests, including a memory check, ribbon alignment test, serial loopback test, and a sensor check. If a test is unsuccessful, an error message appears to notify you.

You can select *None*, which is always the default and does not perform any test; *Memory*, which checks the printer memory; *Ribbon*, which performs a ribbon alignment print test; *Serial*, which checks the serial interface; and *Sensor*, which runs the sensor check. Printer tests are described in detail in the *Solving Problems* section of this guide.

Selecting Print Modes

The second section on the Setup menu is print modes. The most important print mode parameter is emulation, which must be set so that it is compatible with your application program. Selecting print modes change the way text prints on the page.

5) EMUL: AMT Set Printer Emulation



EMUL lets you select a printer emulation for the printer to use. Selecting an emulation enables the printer to imitate some other popular printer. The emulations you can choose from depend on those in the installed Intelli-card(s). On standard printers you can select from the following emulations: *AMT* (AMT's native language); *Diab630* (the Diablo 630 daisywheel printer); *EpsonJX* (the Epson JX color dot-matrix printer); *EpsonLQ* (the Epson LQ-2550 color dot-matrix printer); and *IBMXL24* (the IBM Proprinter XL24 color dot-matrix printer). Always select a printer emulation that is supported by your software. When you select an emulation, all current printer settings remain in effect.

6) QUAL: Letter Set Print Quality

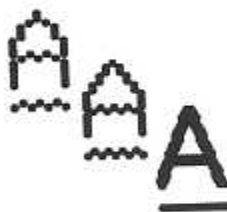

QUAL lets you specify a quality for printing text. You can select *Letter* for letter-quality text; *Memo* for memo-quality text; or *Draft* for draft-quality text. The actual printing speed for each text quality depends on the printer model and the pitch setting.

7) FNT: Courier Set Font

Courier
Gothic
Trend PS
Elite

FNT lets you select a font (type style). The fonts you can choose from depend on those in the installed Intelli-card(s). On standard printers you can select from the following fonts: *Courier*, *Gothic*, *Trend* and *Elite*. When you select a font, the PITCH and CELL settings change to the defaults for the selected font. These defaults ensure that the font is spaced correctly when printed.

8) PITCH: 10 Set Pitch

ABCD
 ABCD
 ABCD

PITCH lets you specify how many characters to print per inch. You can select *10*, *12*, *13.3*, *15*, *17.1*, *20* or *PS* (proportional spacing). The *PS* setting only applies if the current font is a PS font. If you select *PS* and the current font is a fixed-pitch font, the printer uses the default pitch of the font. If the current setting is *Other*, then your software application has set the pitch to some nonstandard value.

When you select a pitch, the CELL setting also changes to your pitch selection to ensure that the font expands or compresses to fit the pitch.

9) CELL: 10 Set Character Cell Size

ABCD
 ABCD
 ABCD

CELL lets you specify how much to expand or compress characters so that they look good when printed at the selected pitch. You can select the same settings as for PITCH; that is, *10*, *12*, *13.3*, *15*, *17.1*, *20* or *PS* (proportional spacing). To select a setting, consider the following:

- ✓ Using the *same* setting for CELL and PITCH yields the best results.
- ✓ Using a *lower* setting for CELL than for PITCH can result in characters that overlap.
- ✓ Using a *higher* setting for CELL than for PITCH can result in wide gaps between characters.

10) LPI: 10 Set Number of Lines Per Inch

ABCDEFGHIJKLMN
 ABCDEFGHIJKLMN
 ABCDEFGHIJKLMN
 ABCDEFGHIJKLMN
 ABCDEFGHIJKLMN
 ABCDEFGHIJKLMN
 ABCDEFGHIJKLMN

LPI lets you specify how many lines to print per inch. You can select *3*, *4*, *6*, *8* or *12* lines per inch. If the current setting is *Other*, then your software application has set the number of lines per inch to some nonstandard value.

11) COLOR: Black *Set Color*

ABCDEF

COLOR lets you specify a color for printing. You can select *Black, Blue, Red, Yellow, Purpl, Green* or *Ornge*. If a monochrome ribbon is installed, the printer ignores your color selection.

12) ITALICS: Off *Turn Italic Mode On and Off*

ABCD

ITALICS lets you turn the italic mode on and off and specify how many degrees the text should slant to the right. You can select *Off, 10°, 20°* or *30°*.

13) HIGH: Off *Turn Double-High Mode On and Off*

ABCDEF

HIGH lets you turn the double-high mode on and off. In double-high mode, characters stretch downward to twice their normal height. You can select *On* or *Off*. When you turn on the double-high mode, the LPI setting changes to three lines per inch. When you turn off the mode, the LPI setting changes to six lines per inch.

14) WIDE: Off *Turn Double-Wide Mode On and Off*

ABCD

WIDE lets you turn the double-wide on and off. In double-wide mode, characters stretch rightward to twice their normal width. You can select *On* or *Off*. When you turn on the double-wide mode, the PITCH and CELL settings change to one-half their current values. When you turn off the mode, these settings return to their original values.

15) SCRIPT: Off *Turn Super/Subscript Modes On and Off*

A^BCD_EEF

SCRIPT lets you turn on and off the superscript and subscript modes. In superscript mode, characters shrink to about half the normal size and print above the print line. In subscript mode, the same small characters print below the normal print line. You can select *Supr* to turn the superscript mode on; *Sub* to turn the subscript mode on; or *Off* to turn both modes off.

16) UNDLINE: Off *Turn Underline Mode On and Off*

ABCDEF

UNDLINE lets you turn the underline mode on and off. In underline mode, all characters and spaces are underlined. You can select *On* or *Off*.

17) BLD/SHA: Off *Turn Bold/Shadow Modes On and Off*

ABCDEF

BLD/SHA lets you turn on and off the bold and shadow modes. In bold mode, characters are printed twice—one on top of the other—to produce bold print. In shadow mode, characters are also printed twice—once and then again slightly offset to the right—to produce shadow print. You can select *Bld* to turn the bold mode on; *Sha* to turn the shadow mode on; or *Off* to turn both modes off.

18) CTR/JST: Off *Turn Center/Justify Modes On and Off*

CTR/JST lets you turn on and off the center and justify modes. In the

CTR/JST lets you turn on and off the center and justify modes. In the

CTR/JST lets you turn on and off the center and justify modes. In the

CTR/JST lets you turn on and off the center and justify modes. In the center mode, the printer centers each line of text between the left and right margins. In the justify mode, the printer expands or compresses each line of text as necessary so that it ends at the right margin. If the printer must expand a line to over twice its original length or compress a line so that characters overlap, the line prints unjustified. With both the center and justify modes, a carriage return or line feed code in the print data marks the end of a line. You can select *Ctr* to turn the center mode on; *Jst* to turn the justify mode on; or *Off* to turn both modes off.

19) LANG: USA Set Language



LANG lets you specify a language for the printer to use when printing text. When you select any language other than *USA*, the printer replaces some of the standard ASCII printable characters with alternate characters that are used in a specific language. You can select the following:

<u>Setting</u>	<u>Country</u>	<u>Character Replacements</u>											
<i>USA</i>	USA	#	\$	@		\		^	'	{		}	~
<i>French</i>	France	#	\$	à	°	ç	§	^	'	é	ù	è	~
<i>German</i>	Germany	#	\$	§	Ä	Ö	Ü	^	'	ä	ö	ü	B
<i>UK</i>	England	£	\$	@		\		^	'	{		}	~
<i>Dansh1</i>	Denmark	#	\$	@	Æ	Ø	Å	^	'	æ	o	å	~
<i>Swedsh</i>	Sweden	#	□	É	Ä	Ö	Å	Ü	é	ä	ö	å	ü
<i>Italn</i>	Italy	#	\$	@	°	\	é	^	ù	à	ò	è	i
<i>Spnsh1</i>	Spain	Pt	\$	@	i	Ñ	í	^	'	ñ	}	~	
<i>Jpnese</i>	Japan	#	\$	@		¥		^	'	{		}	~
<i>Norwgn</i>	Norway	#	□	É	Æ	Ø	Å	Ü	é	æ	o	å	ü
<i>Dansh2</i>	Denmark	#	\$	É	Æ	Ø	Å	Ü	é	æ	o	å	ü
<i>Spnsh2</i>	Spain	#	\$	á	í	Ñ	í	é	'	í	ñ	ó	ú
<i>Portgs</i>	Portugal	#	\$	á	í	Ñ	í	é	ü	í	ñ	ó	ú

20) DIRCTN: Bi-d Set Printing Direction



DIRCTN lets you specify whether the printer should print in both directions or from left to right only. Printing from left to right only provides the highest possible vertical alignment, but slows down printing. You can select *Bi-d* for bi-directional printing or *Uni* for left-to-right printing.

21) DENSITY:Auto

*Set Print Density
(635 and 635d Models Only)*



DENSITY lets you enable and disable automatic forms thickness detection. When set to *Auto*, the printer will automatically detect forms thickness and adjust the printhead for optimal print density.

If necessary, you can disable automatic forms thickness detection and position the printhead a set distance from the platen. To do so, set this parameter to a value from 0 to 30. A setting of 0 moves the printhead as far from the platen as possible and results in the lightest printing; a setting of 30 moves the printhead as close to the platen as possible and results in the darkest printing.

⚠ Caution: Use care when disabling automatic forms thickness detection. If a manual setting is too low, printing may be too light or disappear altogether. If a manual setting is too high, the ribbon can snag on the printhead causing damage to both the ribbon and printhead.

Selecting Page Setup Parameters

The next section of the Setup menu is page setup. Page setup parameters let you specify page size and margins.

22) LENG: 66/6" Set Form Length

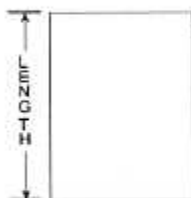

LENG lets you specify the length of the form you are using in 1/6-inch increments. This setting is very important since it controls continuous-forms feeding.

You can select a number from 0 to 182. To determine the correct number to use for your form, multiply the length of the form in inches by 6. For example, if your form is 11 inches long (11 inches \times 6 = 66), you should select 66. When you set form length, the printer sets the top-of-form at the current line and clears the top and bottom margins.

If you set LENG to 0, the printer does not keep track of lines per page. When using single sheets, a form feed control code ejects the page; when using pin-feed paper, a form feed control code performs a carriage return only.

23) WIDTH: 13.6 Set Maximum Print Width



WIDTH lets you specify the maximum print width. If the printer receives a line that exceeds the maximum print width, the excess prints on the next line. You can specify 8, 13.6 or 16 inches. When you select 16, be sure to load paper so that it aligns with the blue line (↑) on the paper scale.

Note: When 16-inch wide printing is selected, printing is unidirectional and slower than normal. Also, draft-quality printing is unavailable. If you select draft-quality printing, the printer will use memo-quality.

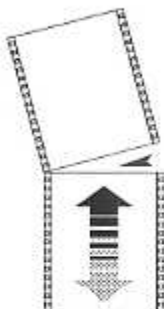
24) DEMAND: Off*Turn Demand Document Mode On and Off*

DEMAND lets you turn the demand document mode on and off. The demand document mode lets you remove a pin-fed form without wasting the next form. With the mode on, pressing the ready button turns printing off, displays DEMND on the control panel, and advances the last printed page up to the tear bar. You can then tear off the page if you want to. Pressing the ready button again causes one of the following actions:

- ✓ If you *removed* the last printed page, the paper reverse feeds to the next top-of-form, the READY message reappears, and printing continues.
- ✓ If you *did not remove* the last printed page, the paper reverse feeds to its original position, the READY message reappears, and printing continues at the point where it left off.

You can select from the following settings:

- ✓ *On* turns the demand document mode on.
- ✓ *Beep* turns the demand document mode on and causes the printer to begin *beeping* 15 seconds after you press the Ready button as a reminder to re-enable printing.
- ✓ *Tear* turns the demand document mode on and causes the printer to reverse feed the paper to the next top-of-form when you re-enable printing, whether or not you actually tear off the last printed sheet. This option is useful when printing thick multipart forms that jam when the leading edge of the form is reverse fed below the printhead.
- ✓ *Auto* causes the printer to advance the bottom of the last printed page to the tear bar whenever the printer is idle; you don't have to press the Ready button. As soon as the printer receives subsequent data to print, the paper reverse feeds as usual.
- ✓ *Off* turns the demand document mode off.

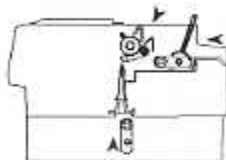

25) PATH: Top

Select Paper Path
(635 and 635d Models Only)

PATH lets you select the active paper path. You can select *Top* to load single sheets from the top of the printer; *Rear* to load pin-feed forms from the rear of the printer; or *Bottom* to load pin-feed forms from the bottom of the printer (635d models only).



26) BIN: None

Select Sheetfeeder Bin

If you are going to use a sheetfeeder option, BIN lets you activate one of the sheetfeeder bins for subsequent paper feeding. Select *None* when you are not using a sheetfeeder; *Front* to feed paper from the front (or only) sheetfeeder bin; *Back* to feed paper from the back sheetfeeder bin; or *Envel* to feed from the envelope tray (if your sheetfeeder has one).

☞ **On 535d and 535dsi models:** You can also select *Bottom* at this parameter to activate the bottom-feed forms tractors. Refer to the *Bottom-Feed Tractors* appendix of this guide for more information.

☞ **On 535, 535si and 635 models:** You can also select *TopTrac* to activate an optional top-mounted pull-tractor. The printer must be idle with no paper loaded when you select *TopTrac*. The printer will automatically switch to the rear paper path and move the printhead back away from the platen. You can then load paper from the bottom of the printer and into the top-mounted pull-tractor. With *TopTrac* selected, all printer functions that perform reverse paper feeding are disabled, including paper park and the demand document mode. Also, the DEMAND, PATH and POPUP parameter settings are ignored.

27) TOP MAR: 000

Set Top Margin



TOP MAR lets you specify a top margin. On subsequent form feeds, paper advances to the top margin you specify. The top margin can be from 0 to 181 lines down from the top-of-form; however, you can only select a line that is above the bottom margin setting. The physical location of the top margin on the page is unaffected by subsequent changes to line spacing. If you change the LENG setting, the top margin resets to 000.

28) BOT MAR: 066 *Set Bottom Margin*

BOT MAR lets you specify a bottom margin. After printing on this line, the printer performs a form feed operation automatically; no printing occurs below the bottom margin. The bottom margin can be from 1 to 182 lines down from the top-of-form; however, you can only select a line that is below the top margin setting. The physical location of the bottom margin on the page is unaffected by subsequent changes to line spacing. If you change the LENG (form length) setting, the bottom margin resets to the new form length.

29) LFT MAR: 000 *Set Left Margin*

LFT MAR lets you specify a left margin. All subsequent carriage returns cause the carriage to move to the left margin. The left margin can be from 0 to 319 character spaces to the right of the far left print position; however, you can only select a character space that is to the left of the right margin setting. To help you visualize left margin locations as you scroll through the possible settings, the carriage moves to the displayed setting. The physical location of the left margin on the page is unaffected by subsequent changes to horizontal spacing (character pitch).

30) RGT MAR: 136 *Set Right Margin*

RGT MAR lets you specify a right margin. When printing reaches the right margin on a line, the printer performs a carriage return/line feed and continues printing on the next line. The right margin is also used in the center and justify modes. The right margin can be from 1 to 320 character spaces to the right of the far left print position; however, you can only select a character space that is to the right of the left margin setting. To help you visualize right margin locations as you scroll through the possible settings, the carriage moves to the displayed setting. The physical position of the right margin on the page is unaffected by subsequent changes to horizontal spacing (character pitch).

Selecting Tabs

The next section of the Setup menu is tabs. The tab parameters let you set and clear horizontal and vertical tab stops.

31) HOR: SET 000 *Set/Clear Horizontal Tab Stop*



HOR lets you set or clear a horizontal tab stop. A horizontal tab stop can be from 0 to 159 character spaces from the far left print position; however, you can only select locations between the left and right margins. When you set a tab stop, the word *SET* appears to the left of the tab stop location. When you clear a tab stop, the word *SET* disappears. To help you visualize tab locations on the page as you scroll through the possible settings, the carriage moves to the displayed setting. If you change the PITCH (characters per inch) setting, the physical locations of tabs change on the page.

32) HOR OP: None *Perform Horizontal Tab Operation*

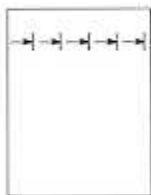

HOR OP lets you clear all horizontal tab stops set previously with the HOR parameter or reset horizontal tab stops every eight print positions across the page. You can select *None* to perform no operation; *Clr* to clear all horizontal tab stops; or *Set8* to clear all horizontal tab stops and reset tab stops every eight print positions across the page.

33) VER: 000 *Set/Clear Vertical Tab Stop*

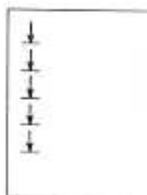

VER lets you set or clear a vertical tab stop. A vertical tab stop can be from 0 to 182 lines down from the top-of-form; however, you can only select lines between the top and bottom margins. When you set a tab stop, the word *SET* appears to the left of the tab stop location. When you clear a tab stop, the word *SET* disappears. If you change the LPI (lines per inch) setting, the physical locations of the vertical tabs change on the page.

34) VER OP: None *Perform Vertical Tab Operation*

VER OP lets you clear all vertical tab stops set previously with the VER parameter. You can select *None* to perform no operation; or *Clr* to clear all vertical tab stops.

Specifying Communications Parameters

The next section of the Setup menu is communications. These parameters control data communications between the printer and the host computer. Before successful communications can occur, these parameters must be set to match those of the host computer. When you change a communications setting, the printer clears the data input buffer.

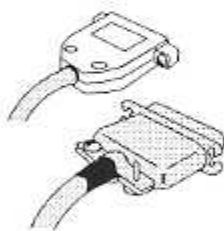
35) INTRFCE: Auto *Select Interface*

INTRFCE lets you select the parallel or serial interface port for communications with the host computer. You can select *Par* for parallel or *Ser* for serial. On 635 and 635d models, you can also select *Auto* for automatic switching between both ports on a first-come, first-serve basis (while receiving data from one port, the printer will set the other port to the busy state). If you select *Ser* or *Auto*, you may also have to set the BAUD, PARITY, DAT BITS, STOP BITS and HNDSHK parameters to match the serial configuration of the host computer. If you select *Par*, these parameters are irrelevant.

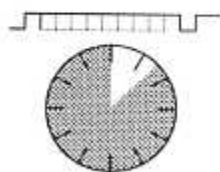
36) BAUD: 9600 *Specify Baud Rate*

BAUD lets you tell the printer what serial baud rate your computer is using. Baud rate is the speed that serial data is transmitted between your computer and the printer. You can select *150*, *300*, *600*, *1200*, *2400*, *4800*, *9600* or *19200*. On 535, 535d, 535si and 535dsi models, you can also select *38400*. Both your computer and the printer must be set to the *same* baud rate.

37) PARITY: None *Specify Parity*

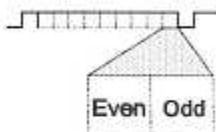

PARITY lets you tell the printer what parity method your computer is using. When your computer uses parity, it adds a special parity bit to each data byte it sends. This parity bit enables the printer to detect a data transmission error. In the even parity method, the sum of the binary 1 bits plus the parity bit must be an even number, or else an error has occurred. In the odd parity method, the sum of the binary 1 bits plus the parity bit must be an odd number, or else an error has occurred. You must select *None* if your computer does not support parity; *Odd* if your computer uses odd parity; or *Even* if your computer uses even parity. Both your computer and the printer must be set for the *same* parity method.

38) DAT BITS: 8 *Specify Number of Data Bits*



DAT BITS lets you tell the printer how many data bits your computer is sending in each byte. You must select 7 if your computer sends 7-bit bytes; 8 if your computer sends 8-bit bytes; or 8M if your computer sends 8-bit data and you want the printer to ignore the most significant bit (MSB).

Note: The 8M setting affects both serial and parallel communications. With the parallel interface active, the 8M setting causes the printer to ignore the signal on the MSB data line.

39) STOP BITS: 1 *Specify Number of Stop Bits*

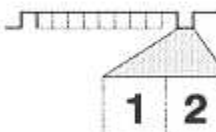

STOP BITS lets you tell the printer how many stop bits your computer is sending in each byte. Stop bits are necessary to separate consecutive bytes in the data stream. You must select 1 if your computer sends one stop bit; or 2 if your computer sends two stop bits.

40) HNDSHK: D/X *Specify Handshaking Method*

HNDSHK lets you tell the printer what handshaking method your computer is using. Handshaking is a technique that starts and stops data

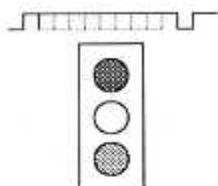

transmission between your computer and the printer. This starting and stopping is important so that neither device receives more data than it can handle at any given time. Without handshaking, the printer's input buffer could overflow.

The printer supports three handshake protocols: DTR, X-ON/X-OFF and ENQ/ACK. DTR is a hardware handshake that uses the Data Terminal Ready line in the serial interface. Both X-ON/X-OFF and ENQ/ACK are software handshakes that require the computer or printer to send certain data bytes on its data transmission line. You can specify *DTR* for the DTR hardware method; *XON* for the X-ON/X-OFF software method; *ENQ* for the ENQ/ACK software method; *D/X* for both the DTR and X-ON/X-OFF methods; *D/E* for both the DTR and ENQ/ACK methods; or *None* for no handshaking method. Both your computer and the printer must use the *same* handshaking method(s).

41) DTR: Pos Set DTR Signal Polarity

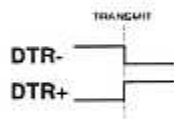

DTR lets you specify the polarity of the extra Data Terminal Ready (DTR) signal in the printer's serial interface. The signal is supplied on pin 25 or pin 11, depending on how the printer is configured. Since most computers use the standard DTR signal on pin 20 for handshaking, this parameter setting is usually ignored. You can select *Neg* for a signal that goes low to enable data transmission; or *Pos* for a signal that goes high to enable data transmission.

42) STROBE: Neg Specify STROBE Pulse Edge for Data Capture

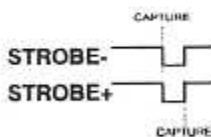

STROBE lets you specify on which edge of the parallel STROBE pulse the printer will capture the data byte. You can select *Neg* to capture data on the leading, negative edge of the STROBE pulse; or *Pos* to capture data on the trailing, positive edge of the STROBE pulse. In most cases, the *Neg* setting will provide reliable data transfer. If your computer's parallel interface sends the STROBE pulse before data has fully settled on the data lines (resulting in data loss), you may be able to correct the problem by selecting the *Pos* setting.

43) BUSY: On *Enable and Disable BUSY Signal*



BUSY lets you enable and disable the parallel BUSY signal. Ordinarily, this signal should be enabled. Some computers, however, do not use this signal so you can disable it. You can select *On* to enable the BUSY signal; or *Off* to disable it. If you disable the signal, the printer keeps the BUSY line high at all times. Since no handshaking occurs, your computer must not send data faster than 50 kilohertz.

44) ACK: On *Enable and Disable ACK Signal*



ACK lets you enable and disable the parallel ACK signal. Ordinarily, this signal should be enabled. Some computers, however, do not use this signal so you can disable it. You can select *On* to enable the ACK signal; or *Off* to disable it. If you disable the signal, the printer keeps the ACK line high at all times. Since no handshaking occurs, your computer must not send data faster than 50 kilohertz.

Selecting Special Modes

The last section of the Setup menu is special modes. These modes let you select a variety of special printing features.

45) HEXMOD: Off *Turn Hexadecimal Mode On and Off*

```

18 19 1A
1B FE 02
FF 06 4F
22 2C 3D
    
```

HEX MOD lets you turn the hexadecimal mode on and off. In the hexadecimal mode, the printer prints the hexadecimal and ASCII representation of every byte it receives:

```

20 21 22 23 24 25 26 27 28 29 2A 2B 2C 2D 2E 2F      !"#%&'()*+,-./
30 31 32 33 34 35 36 37 38 39 3A 3B 3C 3D 3E 3F      0123456789:;<=>?
40 41 42 43 44 45 46 47 48 49 4A 4B 4C 4D 4E 4F      @ABCDEFGHIJKLMNO
    
```

The printer does not interpret or execute any control sequences, nor does it print any text. Hexadecimal mode is useful when you need to view the codes being sent from the host computer to the printer. You can select *On* to turn the hexadecimal mode on; or *Off* to turn the mode off.

46) BUFFER: 060K *Specify Input Buffer Size*

BUFFER lets you change the size of the printer's data input buffer to meet your particular needs. You can specify from 12K up to the total printer memory in 12-kilobyte increments. Memory that you do not allocate for the data input buffer is available to hold downloaded fonts. When you change this parameter, the printer clears the data input buffer and crases all downloaded fonts.

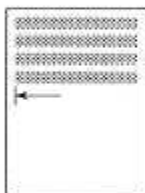
47) AUTO CR: Off *Turn Automatic Carriage Return Mode On and Off*

AUTO CR lets you turn the automatic carriage return mode on and off. In the automatic carriage return mode, the printer performs a carriage return/line feed for each line feed code it receives. You can select *On* to turn the automatic carriage return mode on; or *Off* to turn the mode off.

48) AUTO LF: Off *Turn Automatic Line Feed Mode On and Off*

AUTO LF lets you turn the automatic line feed mode on and off. In the automatic line feed mode, the printer performs a carriage return/line feed for each carriage return code it receives. You can select *On* to turn the automatic line feed mode on; or *Off* to turn the mode off.

47) AUTO FF: Off *Turn Automatic Form Feed Mode On and Off*

AUTO FF lets you turn the automatic form feed mode on and off. In the automatic form feed mode, the printer skips over the perforations of pin-feed paper by setting the top and bottom margins to one-half inch. You can select *On* to turn the automatic form feed mode on; or *Off* to turn the mode off. For the automatic form feed mode to work correctly, the LENG (form length) parameter must be set to the correct form length.



Character sets

50) SETS: IBM1 Select Characters for Codes 128-255

When an Epson or IBM emulation is selected, SETS lets you select a character set for ASCII codes 128 through 255. You can select *IBM1* for IBM set #1; *IBM2* for IBM set #2; *Ital* for the Epson italics set; or *None* for no set (the printer ignores codes above 127). Here are the sets:

ASCII Code	IBM # 1	IBM # 2	Ital	ASCII Code	IBM # 1	IBM # 2	Ital
128	Ç	NUL	Ç	155	ç	ESC	ç
129	ù	ü	ü	156	£	£	£
130	é	é	é	157	¥	¥	¥
131	â	â	â	158	Pt	Pt	Pt
132	ä	ä	ä	159	f	f	f
133	à	à	à	160	á	á	
134	â	â	â	161	í	í	!
135	ç	BEL	ç	162	ó	ó	"
136	ê	BS	ê	163	ú	ú	#
137	ë	HT	ë	164	ñ	ñ	\$
138	è	LF	è	165	Ñ	Ñ	&
139	ï	VT	ï	166	•	•	&
140	î	FF	î	167	◊	◊	'
141	ì	CR	ì	168	¿	¿	(
142	Ä	SO	Ä	169	¬	¬)
143	Å	SI	Å	170	¬	¬	*
144	É	É	É	171	¼	¼	+
145	æ	DC1	æ	172	½	½	'
146	Æ	DC2	Æ	173	;	;	-
147	ô	DC3	ô	174	«	«	.
148	ö	DC4	ö	175	»	»	/
149	ò	ò	ò	176	▒	▒	0
150	û	û	û	177	▒	▒	1
151	ù	ù	ù	178	▒	▒	2
152	ÿ	CAN	ÿ	179			3
153	ö	ö	ö	180	†	†	4
154	Û	SUB	Û	181	‡	‡	5

Character sets—
continued

ASCII Code	IBM # 1	IBM # 2	Ital	ASCII Code	IBM # 1	IBM # 2	Ital
182	⌈	⌈	6	219	■	■	[
183	⌋	⌋	7	220	■	■	\
184	⌌	⌌	8	221	■	■] ^
185	⌍	⌍	9	222	■	■	˘
186	⌎	⌎	:	223	■	■	˘
187	⌏	⌏	;	224	α	α	˘
188	⌐	⌐	<	225	β	β	a
189	⌑	⌑	=	226	Γ	Γ	b
190	⌒	⌒	>	227	π	π	c
191	⌓	⌓	?	228	Σ	Σ	d
192	⌔	⌔	@	229	σ	σ	e
193	⌕	⌕	A	230	μ	μ	f
194	⌖	⌖	B	231	τ	τ	g
195	⌗	⌗	C	232	ϕ	ϕ	h
196	⌘	⌘	D	233	⊖	⊖	i
197	⌙	⌙	E	234	Ω	Ω	j
198	⌚	⌚	F	235	δ	δ	k
199	⌛	⌛	G	236	∞	∞	l
200	⌜	⌜	H	237	∞	∞	m
201	⌝	⌝	I	238	∅	∅	n
202	⌞	⌞	J	239	ε	ε	o
203	⌟	⌟	K	240	∩	∩	p
204	⌠	⌠	L	241	≡	≡	q
205	⌡	⌡	M	242	±	±	r
206	⌢	⌢	N	243	≤	≤	s
207	⌣	⌣	O	244	∫	∫	t
208	⌤	⌤	P	245	∫	∫	u
209	⌥	⌥	Q	246	÷	÷	v
210	⌦	⌦	R	247	≈	≈	w
211	⌧	⌧	S	248	·	·	x
212	⌨	⌨	T	249	·	·	y
213	〈	〈	U	250	·	·	z
214	〉	〉	V	251	√	√	{
215	⌫	⌫	W	252	n	n	
216	⌬	⌬	X	253	z	z	}
217	⌭	⌭	Y	254	■	■	~
218	⌮	⌮	Z	255			

51) PGE END: Off *Select Page End Method*

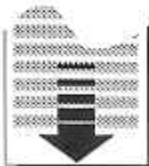

PGE END lets you tell the printer whether or not to use the LENG (form length) setting to determine the last printing line on a cut sheet. You can select *Off* to let printing continue beyond the LENG setting; or *On* to specify that printing stop at the LENG setting.

Regardless of your PGE END setting, the last print line on a cut sheet occurs when the printer receives a form feed control code or printing reaches the physical bottom edge of the page (located automatically by an integral paper sensor).

Most software applications control pagination by sending form feed control codes between pages. In these cases, the PGE END setting should be *Off*. A few software applications do not control pagination directly, but instead send out only line feed control codes between consecutive pages. In these cases, the PGE END setting should be *On*.

Another PGE END setting is *Rll*. Use this setting if you want to feed unsprocketed roll paper into the printer.

52) SLASH-0: Off *Turn Zero Slashing On and Off*

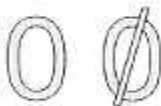

SLASH-0 lets you turn zero slashing on and off. You can select *Off* to specify that the numeral zero be printed without a slash (0); or *On* to specify that the numeral zero be printed with a slash (Ø). Your selection affects the printing of the numeral zero in all fonts and print qualities.

53) AUTOBAIL: Off *Turn Automatic Bail Mode On and Off (535d and 635d Models Only)*

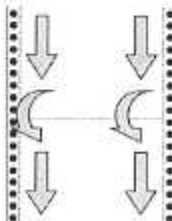

AUTOBAIL lets you turn the automatic bail mode on and off. With the automatic bail mode on, the printer will open the bail each time the perforation of a pin-feed form passes by. After the perforation is clear of the bail, the printer will close the bail. This mode is useful when using thick, multipart forms with perforations that tend to catch on the bail. You can select *On* to turn the automatic bail mode on; or *Off* to turn the mode off.

For the automatic bail mode to work correctly, you must turn the mode on before loading pin-feed paper into the printer and the LENG (form length) parameter must be set to the correct form length.

☞ **Note:** This parameter affects only pin-feed forms fed from the bottom-feed forms tractors.

54) PPR JAM: On *Turn Paper Jam Sensing On and Off (535d, 535dsi, 635 & 635d Models Only)*



PPR JAM lets you turn the printer's paper jam sensing function on and off. With paper jam sensing on, the printer can detect when a pin-feed form gets jammed inside the printer and will notify you by displaying CLEAR PAPER JAM on the control panel display. With paper jam sensing off, the printer cannot detect paper jams. During ordinary operation, you should leave paper jam sensing on. Certain paper stocks, such as high-gloss, exceptionally smooth paper, can cause the printer to falsely detect paper jams. In these rare cases, you can turn paper jam sensing off. You can select *On* to turn paper jam sensing on; or *Off* to turn it off.

55) POPUP: Off *Turn Preprinted Forms Alignment Feature On and Off*

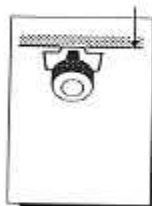

POPUP lets you turn the preprinted forms alignment feature on and off. When the feature is on, you can easily align a preprinted form so that printing begins on any desired line. Just press the Ready button to pause printing and use the Select-dial to align the first print line on the form with the top edge of the ribbon shield. After you press the Ready button, printing will begin on the desired print line. You can select *On* to turn the preprinted forms alignment feature on; or *Off* to turn it off.

56) BLK BAND: Off *Turn Black Band Feature On and Off*



BLK BAND lets you print on preprinted forms containing dark areas. During normal printing, a sensor on the printhead detects paper by "seeing" the whiteness of the paper. Forms with dark areas "fool" the paper sensor resulting in erroneous paper errors. If this occurs, you can set BLK BAND to *On* to correct the problem, however, printing off the bottom of the form is possible if your data is paginated incorrectly.

Reviewing the Setup Menu

Setup menu
summary

Now that you've been introduced to the Setup menu parameters and their possible settings, it's time for a brief review.

Table 4-1. Setup Menu Summary

<i>Parameter</i>	<i>Description</i>	<i>Settings</i>
<i>Operations</i>		
RSTOR	Restore printer settings	None Fctry Usr 1 Usr 2 Usr 3 Usr 4 Usr 5
SAVE	Save printer settings	None Usr 1 Usr 2 Usr 3 Usr 4 Usr 5
DFALT	Select power-on default settings	Fctry Usr 1 Usr 2 Usr 3 Usr 4 Usr 5
TEST	Run printer tests	None Memory Ribbon Serial Sensor
<i>Print Modes</i>		
EMUL	Set printer emulation	AMT Diab630 EpsonJX EpsonLQ IBMXL24
QUAL	Set print quality	Letter Memo Draft
FNT	Set font	Courier Gothic Trend Elite
PITCH	Set pitch	10 12 13.3 15 16 17.1 20 PS Other
CELL	Set character cell size	10 12 13.3 15 16 17.2 20 PS Other
LPI	Set number of lines per inch	3 4 6 8 12 9 Other

Table 4-1. Setup Menu Summary—continued

<i>Parameter</i>	<i>Description</i>	<i>Settings</i>
<i>Print Modes—continued</i>		
COLOR	Set color	Black Red Blue Purpl Yellw Ornge Green
ITALIC	Turn italic mode on and off	10° 20° 30° Off
HIGH	Turn double-high mode on and off	On Off
WIDE	Turn double-wide mode on and off	On Off
SCRIPT	Turn super/subscript mode on and off	Supr Sub Off
UNDLIN	Turn underline mode on and off	On Off
BLD/SHA	Turn bold/shadow modes on and off	Bld Sha Off
CTR/JST	Turn center/justify modes on and off	Ctr Jst Off
LANG	Set language	USA French German UK Danish Swedsh Italn Spnsh1 Jpnese Norwgn Danish2 Spnsh2 Portgs
DIRCTN	Set printing direction	Bi-d Uni
DENSITY	Set print density	Auto 0 to 30
<i>Page Setup</i>		
LENG	Set form length	0/6" to 182/6" (66/6")
WIDTH	Set maximum print width	8 13.6 16

Table 4-1. Setup Menu Summary—continued

<i>Parameter</i>	<i>Description</i>	<i>Settings</i>
<i>Page Setup—continued</i>		
DEMAND	Turn demand document mode on and off	On Beep Tear Auto Off
PATH	Select paper path	Top Rear Bottom
BIN	Select sheetfeeder bin	None Front Back Envel Bottom TopTrac
TOP MAR	Set top margin	0 to 181
BOT MAR	Set bottom margin	1 to 182 (66)
LFT MAR	Set left margin	0 to 319
RGT MAR	Set right margin	1 to 320 (136)
<i>Tabs</i>		
HOR	Set/clear horizontal tab stop	0 to 159
HOR OP	Horizontal tab operation	None Clr Set8
VER	Set/clear vertical tab stop	0 to 182
VER OP	Vertical tab operation	None Clr
<i>Communications</i>		
INTRFCE	Select serial or parallel port	Auto Par Ser
BAUD	Specify baud rate	150 300 600 1200 2400 4800 9600 19200 38400
PARITY	Specify parity	Odd Even None
DAT BITS	Specify number of data bits	7 8 8M
STOP BITS	Specify number of stop bits	1 2

Table 4-1. Setup Menu Summary—continued

<i>Parameter</i>	<i>Description</i>	<i>Settings</i>
<i>Communications—continued</i>		
HNDSHK	Specify handshaking method	D/X DTR XON ENQ D/E None
DTR	Set DTR signal polarity	Pos Neg
STROBE	Specify STROBE pulse edge for data capture	Pos Neg
BUSY	Enable and disable BUSY signal	On Off
ACK	Enable and disable ACK signal	On Off
<i>Special Modes</i>		
HEX MOD	Turn hexadecimal mode on and off	On Off
BUFFER	Specify input buffer size	Depends on how much memory is installed (60K)
AUTO CR	Turn automatic carriage return mode on and off	On Off
AUTO LF	Turn automatic line feed mode on and off	On Off
AUTO FF	Turn automatic form feed mode on and off	On Off
SETS	Select characters for codes 128 through 255	Roman8 IBM1 IBM2 Ital None
PGE END	Select page end method	On Off Rll

Table 4-1. Setup Menu Summary—continued

<i>Parameter</i>	<i>Description</i>	<i>Settings</i>
<i>Special Modes—continued</i>		
SLASH-0	Turn zero slashing on and off	On Off
AUTOBAIL	Turn automatic bail mode on and off	On Off
PPR JAM	Turn paper jam sensing on and off	On Off
POPUP	Turn preprinted forms alignment feature on and off	On Off
BLKBAND	Turn black band feature on and off	On Off

Section

5

Cleaning and Maintenance

To maintain trouble-free operation and good print quality, you should perform periodic cleaning and preventive maintenance procedures on your printer. This section provides the following procedures:

- ✓ Cleaning the platen and bail rollers
- ✓ Cleaning the main carriage shaft
- ✓ Cleaning the printhead wires
- ✓ Cleaning printer surfaces
- ✓ Inspecting printer parts
- ✓ Replacing the ribbon cartridge
- ✓ Replacing the printhead
- ✓ Replacing the fuse

